

LUBRICATE ALL SEALS WITH CLEAN HYDRAULIC OIL PRIOR TO ASSEMBLY.  
DO NOT USE SILICONE BASED LUBRICANTS.

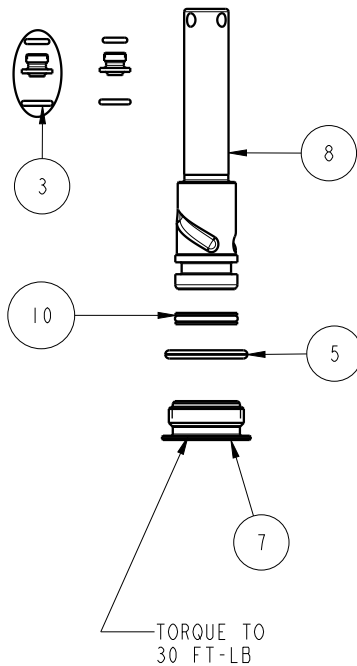

N/A	N/A	6V254200	SEAL KIT, FKM	N/A	NOTED
N/A	N/A	60254200	SEAL KIT, STANDARD	NOTED	
10	1	39H10018	SEAL,T, (11/16 X 5/32 X 7/8)	X	39V10018
9	1	39F54001	BU RING, (-208 CUSTOM)	X	X
8	1	81510901	PLUNGER, SC, 1100#		
7	1	81400029	RETAINER,SC,HS,1100		
6	1	39053001	WIPER,SNAP-IN, (5/8)	X	X
5	1	39051031	O-RING, (-912)	X	X
4	1	39010020	SEAL,BEVEL W/HEEL INSERT,5/8 x 1/8 x 7/8	X	39V10020
3	2	30871120	ASSY, ADAPTER, SC, TF, MM	X	30871120F
2	2	30601144	PLUG, SOCH, SAE 4		
1	2	30601122	PLUG, SOCH, SAE 2		
<b>No.</b>	<b>QTY</b>	<b>PART No.</b>	<b>DESCRIPTION</b>	<b>Std. Seal kit</b>	<b>FKM Seal Kit</b>

### PARTS LIST

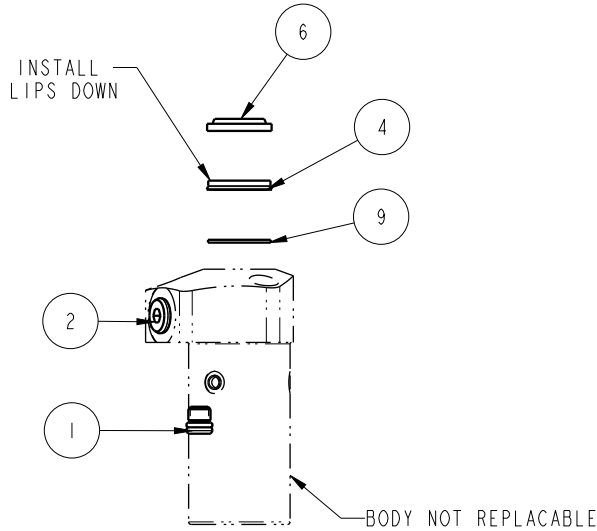

VEKTEK, INC.  
1334 E. SIXTH AVE. P.O. BOX 625  
EMPORIA, KS. 66801 U.S.A.

ASSEMBLIES AFFECTED  
25620900  
25620900F

PARTS LIST ASSY,CYL,PP,TF,3000/1400

SIZE  
A PL2512

REV  
B

B	4651	RELEASE	RLK	3/30/22
REV	IN ACCORDANCE WITH ECN	EFFECTIVE DATE	REVISED BY	DATE
DRW BY:	RLK	<b>DRAWING STATUS: Released</b>		
DATE:	5/21/21	PRODUCTION APPROVED FOR RELEASED STATUS ONLY		

SHEET 1 OF 2

FORM FEG035\_PL\_ASIZE, REV. B

1	1	BUTTON HEAD CAP SCREW	21-4110-01	21-0100-20	21-4100-39	NO	NO	NO
2	1	WIPER, ROD (FLUOROCARBON)	39-0530-04	39-0530-01	39-0530-00	YES	YES	NO
3	1	BACK-UP RING, ROD	39-F540-00	39-F540-01	39-F540-02	YES	YES	NO
4	1	SEAL, ROD (STANDARD)	39-0100-38	39-0100-20	39-0110-46	YES	NO	NO
	1	SEAL, ROD (FLUOROCARBON)	39-0520-14	39-V100-20	39-V110-46	NO	YES	NO
5	3	BALL, TUNGSTEN CARBIDE		23-6000-11	23-6500-04	YES	YES	NO
6	3	BALL SEAT ASSEMBLY		90-1999-89	90-1999-58	YES	YES	NO
7	1	PLUNGER		81-6109-01	81-4000-21	NO	NO	NO
8	1	SEAL, PLUNGER (STANDARD)	39-0100-36	39-0100-15	39-0110-27	YES	NO	NO
	1	SEAL, PLUNGER (FLUOROCARBON)	39-0520-10	39-0520-11	39-0520-12	NO	YES	NO
9	1	GASKET	39-T550-01	39-T550-02	39-T550-03	YES	YES	NO
10	1	RETAINER	81-5305-01	81-5309-02	81-5313-00	NO	NO	NO
11	1	O-RING (STANDARD)	39-0000-57	39-0010-42	39-0010-40	YES	NO	NO
	1	O-RING (FLUOROCARBON)	39-0510-31	39-0510-18	39-0510-29	NO	YES	NO
12	1	O-RING (STANDARD)	39-0000-56	39-0010-41	39-0010-39	YES	NO	NO
	1	O-RING (FLUOROCARBON)	39-0510-26	39-0510-19	39-0510-28	NO	YES	NO
13	2	BACK-UP RING (STANDARD)	39-0100-54	39-0110-80	39-0210-06	YES	NO	NO
	2	BACK-UP RING (FLUOROCARBON)	39-0540-24	39-0540-00	39-0110-68	NO	YES	NO
14	1	BALL, PIVOT	23-6000-14	23-6000-11	23-6000-02	NO	NO	YES
15	1	DISK, PIVOT	N/A	81-5909-01	81-5913-01	NO	NO	YES
16	1	ROD, SPRING SUPPORT	81-5905-01	N/A	N/A	NO	NO	NO
17	1	SPRING, INNER	23-3100-08	23-3110-13	23-3130-09	NO	NO	YES
18	1	SPRING, OUTER	23-3110-17	23-3130-08	23-3130-10	NO	NO	YES
19	1	FILTER	N/A	31-0910-06	31-0910-06	NO	NO	NO
N/A	N/A	SEAL KIT (STANDARD)		60-1501-37	60-1501-38	INCLUDED IN KIT		
N/A	N/A	SEAL KIT (FLUOROCARBON)		6V-1501-37	6V-1501-38			
N/A	N/A	SPRING KIT		6I-1503-15	6I-1503-15			
N/A	N/A	INSTALLATION INSTRUCTIONS	IS-1504	IS-1504	IS-1504	INCLUDED WITH PARTS LIST		

<b>PARTS LIST</b>	 <b>VEKTEK</b> <sup>®</sup> VEKTEK, INC. 1334 E. SIXTH AVE. P.O. BOX 625 EMPORIA, KS. 66801 U.S.A.
	ASSEMBLIES AFFECTED: <b>PARTS LIST, PARTS LIST, CYL, PULL, CH</b>
SIZE A: <b>PL2512</b>	REV B:

B	4651	RELEASE	RLK	3/30/22
REV	IN ACCORDANCE WITH ECN	EFFECTIVE DATE	REVISED BY	DATE
DRW BY: ABC	<b>DRAWING STATUS: Released</b> PRODUCTION APPROVED FOR RELEASED STATUS ONLY			
DATE: XX-YY-ZZ				

SHEET 2 OF 2